

## Easy Step™ 1000 Stepper Driver Module

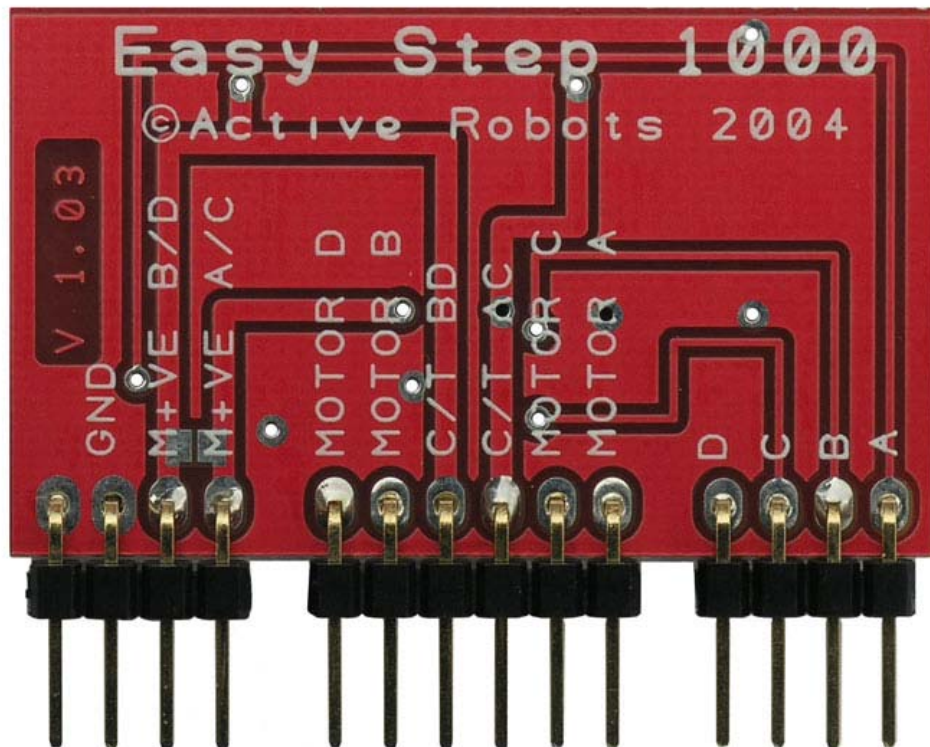

STEPPER MOTOR DRIVER MODULE



# ACTIVE ROBOTS

## Example Connection Diagram

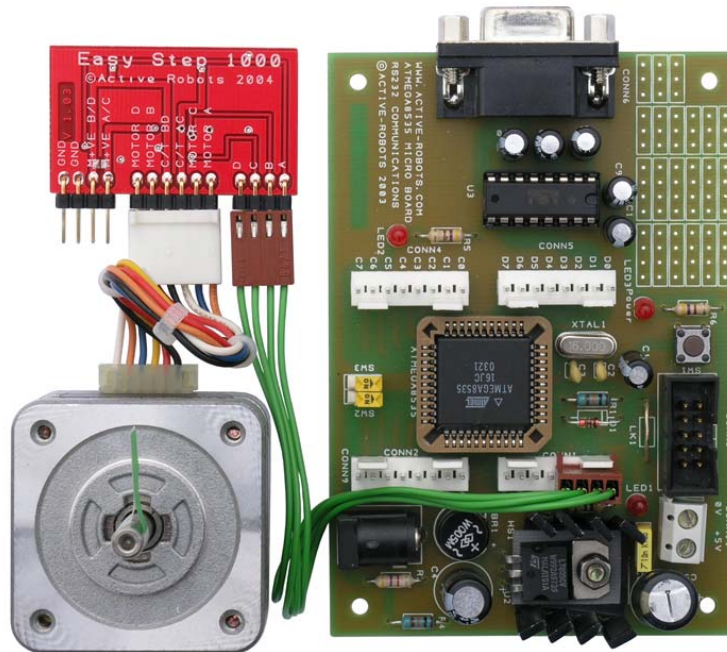
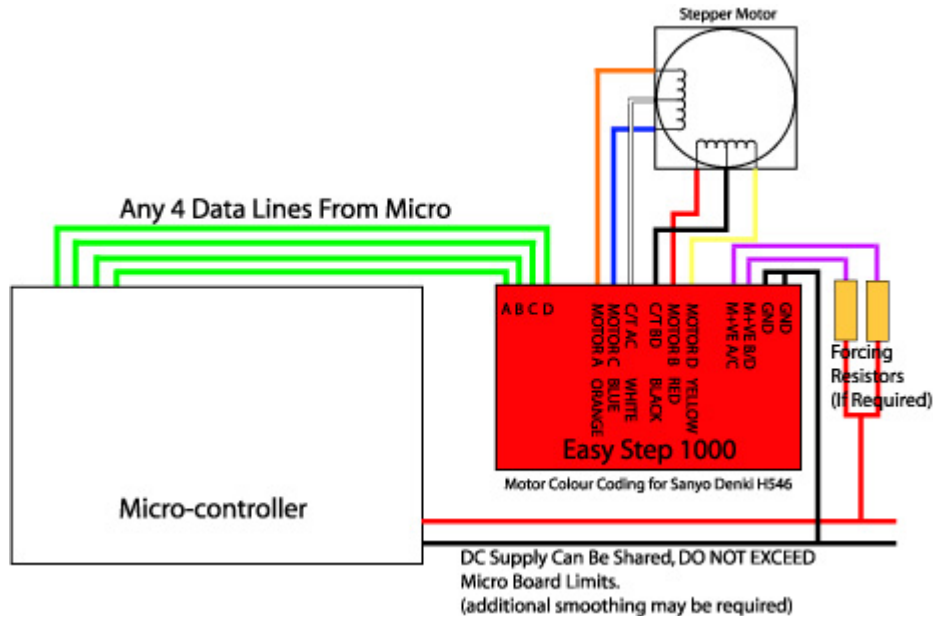

# ACTIVE ROBOTS

The Easy Step™ 1000 (ES1000) is intended to be the link between a microprocessor and stepper motor. The ES1000 module provides a quick and easy route for driving stepper motors, (without the cost of an 'intelligent' module which usually results in redundancy in the controlling micro).

The small size and high current handling capabilities of the ES1000 modules make them ideal for inclusion in robotics and general control applications. The ease of use of the ES1000 modules allows their rapid incorporation into any project. Free demonstration software is available, making the building and control of a robot simple and quick.

The ES1000 module provides all of the high speed, high current switching necessary via MOSFETS to control any stepper motor up to 3A per phase. You can use any mode supported by your software, such as Full, Half or Wave step modes. All connections to the module are provided by industry standard 0.1" connectors in 3 banks.

Bank 1. This is the input from the micro controller and the 4 lines are marked A, B, C, D. By switching these lines in the correct sequence, any of the stepping modes can be implemented.



# ACTIVE ROBOTS

The table below shows the four steps necessary to implement Full step mode.

Step	A	B	C	D
1	X		X	
2		X	X	
3		X		X
4	X			X

The sequence is repeated as many times as necessary. The sequence can be stopped at any time, (allowing for motor deceleration if necessary) and the sequence restarted at any point.

Sample BASCOM AVR software is available demonstrating how to build a PC interface to the [Active Micro Board](#) and a ES1000 driver board connected to our [H546 stepper](#) motors.

Bank 2. The second connector on the module is a 6 way industry standard 0.1" connector, the 6 connections to the stepper motor are clearly marked for our H546 stepper motors, any other can be connected, but the wire colour on your motor may differ.

Bank 3. The third connector on the stepper driver board is the Power/Ground connection. The two Pins marked M+ VE(B/D & A/C respectively) are for the positive feeds to the motors, these would normally be via 'forcing' resistors to increase the torque of the motor.



# ACTIVE ROBOTS

Up to 35 volts can be safely applied to the ES1000 module. However, we would recommend that the motor wires are not disconnected while the power is applied.

The Ground must be connected to a common ground for the Data signal and motor power supply. Although 2 ground connections are provided, only 1 need be used with 1 Amp motors. Also provided on the pin side of the board are 2 small solder pads (illustrated in figure 3 below) that can be bridged to allow use of a common power supply to both motor +VE's when the Easy Step 1000 is being used without forcing resistors or in wave mode.

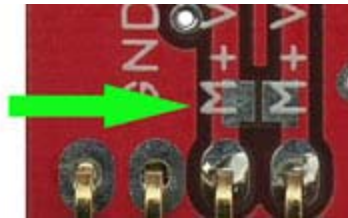

Figure 3

The small size of the ES1000 and high current handling capabilities, make them ideal for inclusion in robotics and general control applications. The ease of use of the ES1000 will allow their rapid incorporation into any project. The demo software available will make the building and control of a robot simple and quick, (giving the builder the ability to tailor the software for their application).

